

Weatherization and Insulation - WINDOW INSULATION SHRINK FILM KIT

Window insulation kits provide a cost-effective solution for improving building energy efficiency. The shrink film and tape create an airtight seal, reducing drafts, condensation, and heat loss. This helps lower energy consumption and heating/cooling costs.

PRODUCT SPECIFICATIONS

Material	Crystal-clear shrink film
Thickness	0.6 mil

DETAILED DIMENSIONS

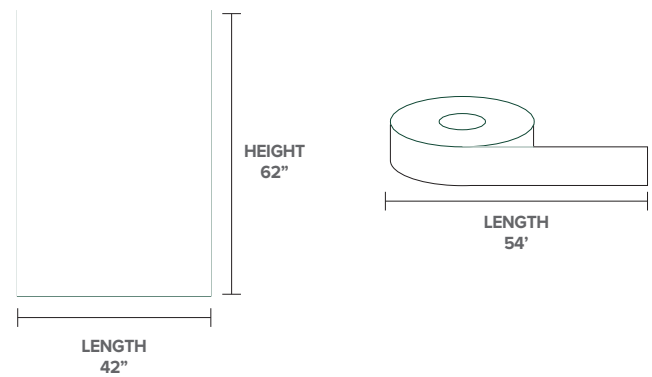

FEATURES

- Economical energy-saving solution
- Save up to 35% of heat loss
- Hot & cold air loss prevention
- Tailored size and easy installation
- Increases R-value by 90% over an average single pane window
- Shrinks tight for wrinkle-free, clear-as-glass results

KIT INCLUDES

- 3 Plastic crystal-clear sheets
- 2-way tape

MODEL INFORMATION

MODEL NUMBER	CASE QTY
WX/WI/3	48

1-877-255-0004 | info@greenliteusa.com

www.greenliteusa.com

V2-012025

