

## LED Fixtures - DUSK-TO-DAWN NITE LITE

Automatic light-sensing technology for enhanced safety and convenience. Save energy and enjoy reliable illumination in hallways, stairwells, and more.



### PRODUCT SPECIFICATIONS

<b>Wattage</b>	0.3W
<b>Lumens</b>	5LM
<b>Lifetime</b>	25,000 hours
<b>Function</b>	Dusk to Dawn
<b>Color Temperature</b>	3000K
<b>LED Model</b>	2835
<b>Ra/CRI</b>	Ra > 80
<b>Beam Angle</b>	110°
<b>Control</b>	CDS
<b>Material</b>	PC + ABS
<b>Certifications</b>	ETL/CETL, FCC
<b>Warranty</b>	2 years

### DETAILED DIMENSIONS

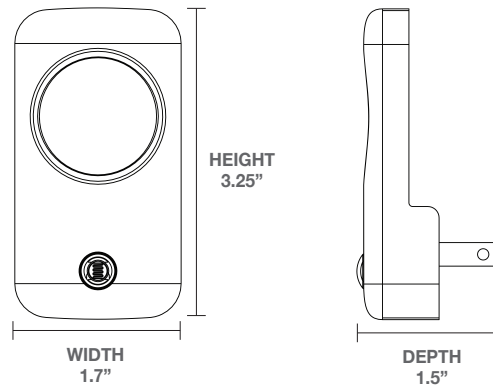

### FEATURES

- OFF in the day, ON at night
- Dusk-to-dawn sensor
- Added safety and security
- Cool-to-touch

### MODEL INFORMATION

MODEL NUMBER	PACK SIZE	CASE QTY
NLDD/25/2	2	48

1-877-255-0004 | [info@greenliteusa.com](mailto:info@greenliteusa.com)

[www.greenliteusa.com](http://www.greenliteusa.com)

V1-012325

