

Air Quality and Home Safety - DEHUMIDIFIER

Fight dampness and protect your home with the Greenlite ENERGY STAR Dehumidifier. This powerful unit offers efficient moisture removal with a unique lift-and-twist design for flexible operation and 3x the water tank capacity. Control it from anywhere with your smartphone or voice assistant using the App. Plus, get notified when it's time to empty the bucket!



PRODUCT SPECIFICATIONS

Power Supply	115V,1Ph,60Hz
Input Wattage	230W
Plug Type	Parallel/NEMA 5-15
Power Cord Type	16AWGx3
Dehumidification	20.16 pint/day
Bucket Size (Liters)	12L
Removable Bucket	Yes
Airflow Roomside (hi / low)	150.00 / 126.47 CFM
Noise level	42 - 48 dB(A)
Refrigerant	R32
EEV	1.7 L/kWh
Fan Speeds	Low, Med, High
Filter Type	Air Fresh Filter
Clean Filter Indicator Light	Yes
Remote Control	Yes
Control Type	Electronic
Wi-Fi Ready	Yes
App Compatibility	Amazon Alexa, Google Assistant
Voice Control	Yes
Operating Temperature	41-96F
Adjustable Humidistat	Yes, 35%-85%
Color	White
Net Weight	15 lbs
Bucket Fill Indicator	Yes
Automatic Shutoff	Yes
Automatic Defrost Control	Yes
Certifications	Energy Star, UL

DETAILED DIMENSIONS

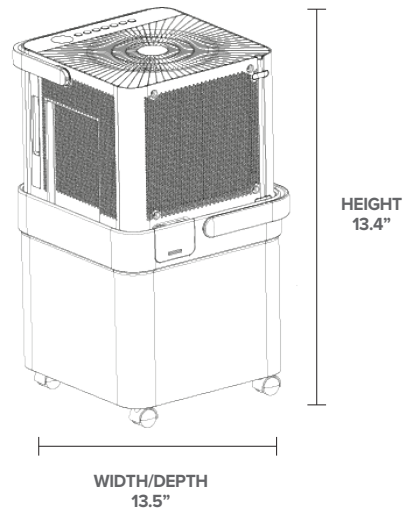

FEATURES

- Real-time humidity and water levels
- Efficient moisture removal
- Lift-and-twist design
- Smart home connectivity
- Remote drain option

