

Air Quality and Home Safety - SMOKE DETECTOR

Reliable 9V Battery-Operated Smoke Detector - Meets Industry Standards. Ensure code compliance and dependable fire safety with this photoelectric smoke detector. Powered by a 9V battery, it provides early warning of smoke and fire, crucial for protecting lives and property.



PRODUCT SPECIFICATIONS

Power Source	9V battery
Sensor	Photoelectric
Alarm Volume	≥ 85dB(A) @ 10 feet
Indicator Light	Red LED
Alarm Mode	Sound and light signal
Temperature Range	4.4°C (40°F) to 37.8°C (100°F)
Humidity Range	10-95% Relative humidity, non-condensing
Mounting Type	Ceiling or wall
Unit Weight	137g (including battery)
Warranty	3-year limited
Standard	UL STD 217 9th ED

DETAILED DIMENSIONS

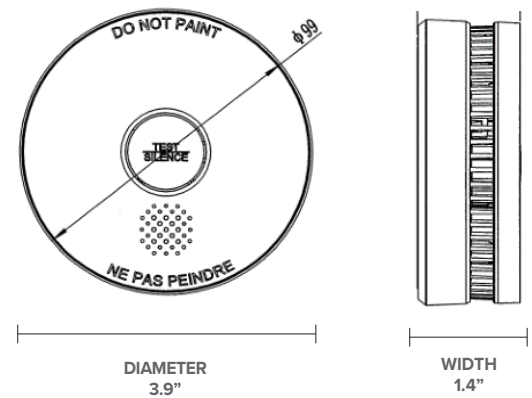

FEATURES

- Reliable early detection with advanced photoelectric technology
- Simple, wire-free installation and low-battery indicator
- Includes a built-in test button for regular functionality checks

MODEL INFORMATION

MODEL	CASE QTY



1-877-255-0004 | info@greenliteusa.com

www.greenliteusa.com

V1 - 20250120

